

VRLA Refined Lead Technical Datasheet

Uses

Nyrstar VRLA Refined Lead is a high-purity bismuth-enhanced product suitable for all types of batteries, and is used by battery companies world-wide.

Chemical specification

Chemical specification	Guaranteed analysis
Bi	0.05 – 0.06 %
Ag	≤ 0.001%
As	≤ 0.0001%
Ba	≤ 0.0005%
Cd	≤ 0.0005%
Co	≤ 0.0001%
Cr	≤ 0.0002%
Cu	≤ 0.001%
Fe	≤ 0.0002%
Mo	≤ 0.0003%
Mn	≤ 0.0003%
Ni	≤ 0.0002%
S	≤ 0.0007%
Sb	≤ 0.0001%
Se	≤ 0.0001%
Sn	≤ 0.0005%
Te	≤ 0.00003%
V	≤ 0.0002%
Zn	≤ 0.0005%

Physical data

Physical property	Unit	Value
Density	solid (@ 20°C) liquid (@ 327.3°C)	11.337 10.686
Melting point	°C	327.3

Available shapes/package

Shape/package	Nominal weight (in kg)	Dimensions (in mm)
Ingot	25	592 x 80 x 69
Ingot bundle (42 ingots per bundle)	1050	592 x 592 x 476

VRLA Refined Lead Technical Datasheet

Ingot

Nominal mass 25 kg
Dimensions 592 x 80 x 69

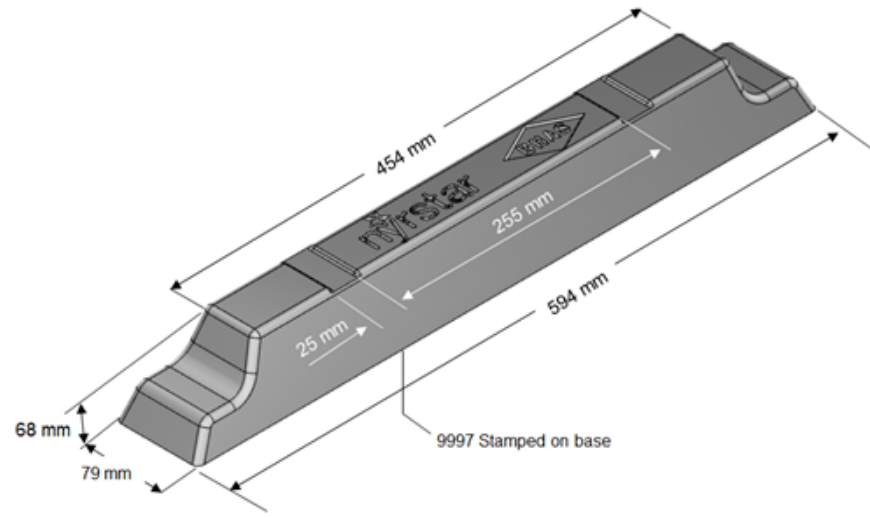

Ingot bundle (42 ingots per bundle)

Nominal mass 1050 kg
Dimensions 592 x 592 x 476

